

# KALORINA K 2209 - CL5 Wood chips

## Biomass boiler

### Technical data

KALORINA			K 2209 - CL5 Wood chips
Carrier fluid			Water
Power on furnace		kW	97,8
Nominal Power		kW	90,0
Reduced Power		kW	25,0
Thermal efficiency		%	92
Boiler class	EN 303-5:2012		5

### CONSTRUCTION DATA <sup>(1)</sup>

Dimensions	Width		1.866
	Depth	mm	1.513
	Height		1.323
Dimensions of the door for cleaning	( B )	mm	554
Min length for auger extraction		mm	1590
Combustion chamber volume		m <sup>3</sup>	0,24
Fuel supply			Extraction system by auger
Weight		kg	700
Flue diameter	( D )	φ mm	200
Boiler body			Steel
Combustion chamber			Four wet walls
Brazier			In stainless steel with cast iron elements
Boiler body isolation			In high density material, panels in steel painted with anti-corrosion epoxy powder
Hopper volume		litres	380

### Hydraulic data

Hydraulic pressure test		bar	6
Max working pressure		bar	3
Boiler water content		litres	240
SLEEVES UNI/DIN EN 10241-ST 37	delivery		DN 50 V
	return	φ mm	DN 40 V
	expansion tank		DN 25 V
Residual power dissipator	Input	φ mm	DN 14
	Output	φ mm	DN 14
Expansion tank			Open / Closed
Loading drop in the water side 20 K		mBar	110,0

### TECHNICAL DATA

KALORINA K 2209 - CL5 Wood chips

### Operating data

Draught Pressure		Pa	20 ± 20%
Smoke temperature		°C	120± 30%
Max working temperature	water	°C	90

Combustion chamber temperature		°C	900
Power modulation			Automatic on water and fumes
Fuel flow regulation			Modulating electronic
Combustion air flow regulation			Modulating electronic
Chimney flue ash discharge			Manual, through ash tray on the machine
			Standard automatic
Cleaning system of tube bundle heat exchanger			Solenoid valves, air injection Sleeves, multi nozzles, general three-way valve, pressure reducing valve, flexible security, electronic adjustment of the system.
Combustion chamber ash discharge			Manual
Ash tray volume		litres	29,0

## Fuel <sup>(2)</sup>

Recommended class			WOOD CHIPS : EN 14961 - 5
Fuel consumption at nominal power		kg/h	22,40
Fuel consumption at reduced power		kg/h	5,80
CO Emissions (10% of O <sub>2</sub> )			Class 5 according to EN 303-5:2012
Dust (10% of O <sub>2</sub> )			< 20 mg/Nm <sup>3</sup>
Environmental class		stars	4

## Smoke treatment system

Technology			Dry abatement
Collapsible pollutants			Combustion powders
Structure and self-supporting casing			Painted steel sheet of adequate thickness
Functional description			Composed of a double decantation chamber with decanted unburned collection. An electric fan placed between the cyclone and the chimney ensures constant depression inside the boiler (optional - necessary due to lack of draft). The technology is used for the removal of large particle size powders.

## Electrical data <sup>(3)</sup>

Control and adjustment unit			Electronical for the control and programmed management of combustion via a flue gas temperature probe and a boiler temperature probe, safety timers, shutdown due to ignition failure and various alarms. It's composed of motherboard, thermoregulator, menu with on-line guide that allows the electronic management of the system with signaling of the operating status and signaling of alarms
Ignition			Electronic through 250 W resistor
Installed electrical nominal power		W	1160
Average of nominal absorbed electrical power		W	264
Nominal voltage		V	230
Nominal frequency		Hz	50
Nominal current		A	6,90

## Arrangement

Room Thermostat			Output connection
Remote assistance			Through RS 232 connection

## TECHNICAL DATA

**KALORINA K 2209 - CL5 Wood chips**

## Optional

Hopper position			Right / Left
Combustion control			Through Lambda probe
Remote control system			Through Wi-fi module
Remote assistance			Software for management and control via Wi-Fi
Combustion smoke evacuation system			Forced draft aspiration

## Security system

			Antifreeze programming
Signaling and control			Through boiler probe
Control and boiler block			Through smoke probe

		Manual reset thermostat
		Boiler block for open door
		Sensor of ending fuel
Functioning errors		Through visual and / or acoustic alarms
		Inspection viewer of combustion chamber
		Differential pressure switch
Combustion control		Shutdown due to ignition failure and various alarms
Smoke disposal in emergency		Through Lambda probe (if present)
		Through suction fan in emergency function (if present)

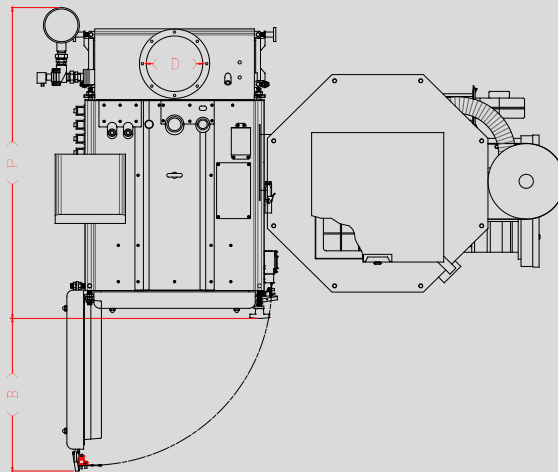
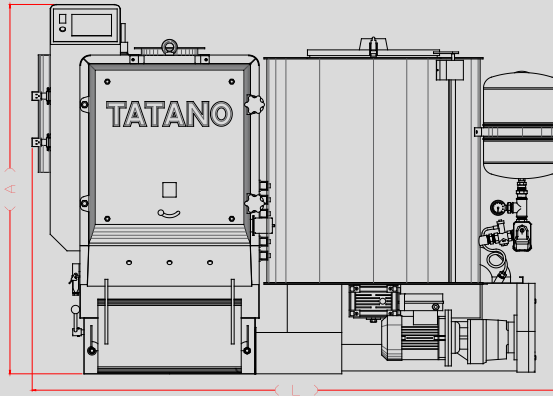

( 1 ) The dimensions may vary depending on the position of the hopper, on the control panel position or in addition of optional accessories or for constructive choices.

( 2 ) All data concerning the fuel consumption and the environmental emissions may vary according to the characteristics of the fuel used, the operating conditions and the presence of the smoke treatment system.

( 3 ) All data can vary according to electrical components (motors, fans etc.). The actual data will be reported in the plate attached to the boiler.

The company reserves the right to change dimensions and features without prior notice, disclaims any liability for transcription or printing errors.