

# KALORINA K 135 LE-PA

## *Biomass Boiler*

### Data sheet

KALORINA			K 135 LE-PA	
Carrier Fluid			Water	
Power on furnace		kW	146	
Nominal Power		kW	135	
Reduced power		kW	29	
Thermal efficiency min-max		%	90-93	
Boiler class	EN 303-5:2012		5	

### Construction data (1)

Dimensions	Width		2.061
	Depth	mm	2.502
	Height		2.050
Dimensions of the opening door for cleaning		mm	611
Dimensions of the inspection viewer	Width	mm	60
	Height		200
Min lenght for the auger extyraction		mm	1868
Combustion chamber volume		m <sup>3</sup>	0,57
Fuel feeding			Extraction system through auger
Weight		kg	2370
Chimney diameter		φ mm	200
Boiler body			Steel
Combustion chamber			Four wet walls
Brazier			Feeding from the bottom in inox steel and cast iron elements
Boiler body isolation			In high density material, infill panels made in anti-corrosion epoxy powder coated steel

**Hydraulic data**

Max working pressure		bar	3
Hot water content		litri	441
Flange connection DIN 2986-UNI228-ST37	delivery	φ mm	DN 65 V
	return		DN 65 V
	Expansion tank		DN 65 V
Residual power Heat sink	Inlet	φ mm	DN 14
	Outlet		DN 14
Expansion tank			Open/Closed
Heat loss water side 20 K		mBar	21,0

**Functioning features**

Draught pressure		Pa	30 ± 20%
Smoke temperature		°C	100 ± 30%
Max working Temperature	water	°C	90
Combustion smokes evacuation			Forced exhaust draught
Power modulation			Automatic for water and smokes
Fuel flow adjustment			Electronic modulating
Combustion air flow adjustment			Electronic modulating
Chimney flue ash discharge			Manual, through ash tray on board
			Automatic standard
Heat exchanger Cleaning system			Solenoid valves, air injection sleeves, Multi nozzles, general three-way valve, pressure reducer, safety Flexible, electronic control system.
Combustion chamber ash discharge			Automatic through motorized auger
Ash tray		litres	87

**Fuel <sup>(2)</sup>**

Class to be used			PELLET : EN 14961 - 2 (Class A1 - A2)
Fuel consumption with nominal power		kg/h	30,59
Reduced consumption with nominal power		kg/h	6,61
Smokes flow at nominal power		g/s	80,4
Emissions CO (10% of O <sub>2</sub> )		mg/Nm <sup>3</sup>	< 500
Emissions CO (13% of O <sub>2</sub> )		mg/Nm <sup>3</sup>	< 250
Rewarding Coefficient of dusts			1,5

**Smoke treatment system**

Type of technology			Multi-cyclonic with Felling dry
Type of dust separation			Centrifugal
Foldable pollutants			Dust combustion
Structure and self-supporting case			Painted sheet steel of suitable thickness
Disposition of cyclones			Vertical units arranged in parallel
Functioning description			Consists of an inner chamber with a series of little ccyclones extolling the ashes depositing them into a trayer on the machine. An electric fan positioned between the cyclone and the chimney ensures the constant negative pressure in the boiler. Thanks to the centrifugal force the dust particles are separated from the gas stream which has been imposed on the rotary flow. The technology is used for the removal of powders of larger particle diameter.

**Electrical data <sup>(3)</sup>**

Control panel			Steel cabinet with sealing gaskets composed of components for manual and automatic system for the programming and control, such as: contactors, cycle programmers, timers, control switches, operating lights, USB connectivity, visual and/or acoustic signals
Adjustment and control unit			electronic type for the control and the management of the combustion through flue gas temperature and boiler temperature probes, detection sensor, safety timers, stopping due to ignition failure and various alarms. It's composed of motherboard, controller, menus with online help that allows the electronic management system with the operation status and alarm signaling
Ignition			Electronical through ignitor
Electrical power		W	5240
Medium Nominal electrical power		W/h	962
Nominal voltage		V	400 + N
Nominal frequency		Hz	50
Nominal current		A	16,32
Absorbed Average nominal current		A/h	2,00

**Arrangement**

Room Thermostat			Output connection
Remote assistance			Through RS 232 connection

**Optional**

Hopper position			right / left /rear side
Suction fan position			right / left /rear side
Combustion control			through Lambda Probe
Remote control			Through GSM module
Remote assistance			Software for the managing and control through Wi-Fi or internet module

**Security system**

Alarm and control			Antifreeze programming
Boiler Control and lock			Through boiler probe
			Through smoke probe
			Manual resetting thermostat
			Boiler stop for open door
			End fuel sensor
Functioning error alarms			Through visual and acoustic alarms
			Inspection viewer of the combustion chamber
			Differential Pressure switch
			Pressure switch
			Emergency Button
			stop for ignition fail and various alarms
Combustion control			through Lambda probe
Antifire system			Flow control group with thermostatic valve and temperature sensor
Smokes evacuation in emergency			Through exhaust fan in emergency function

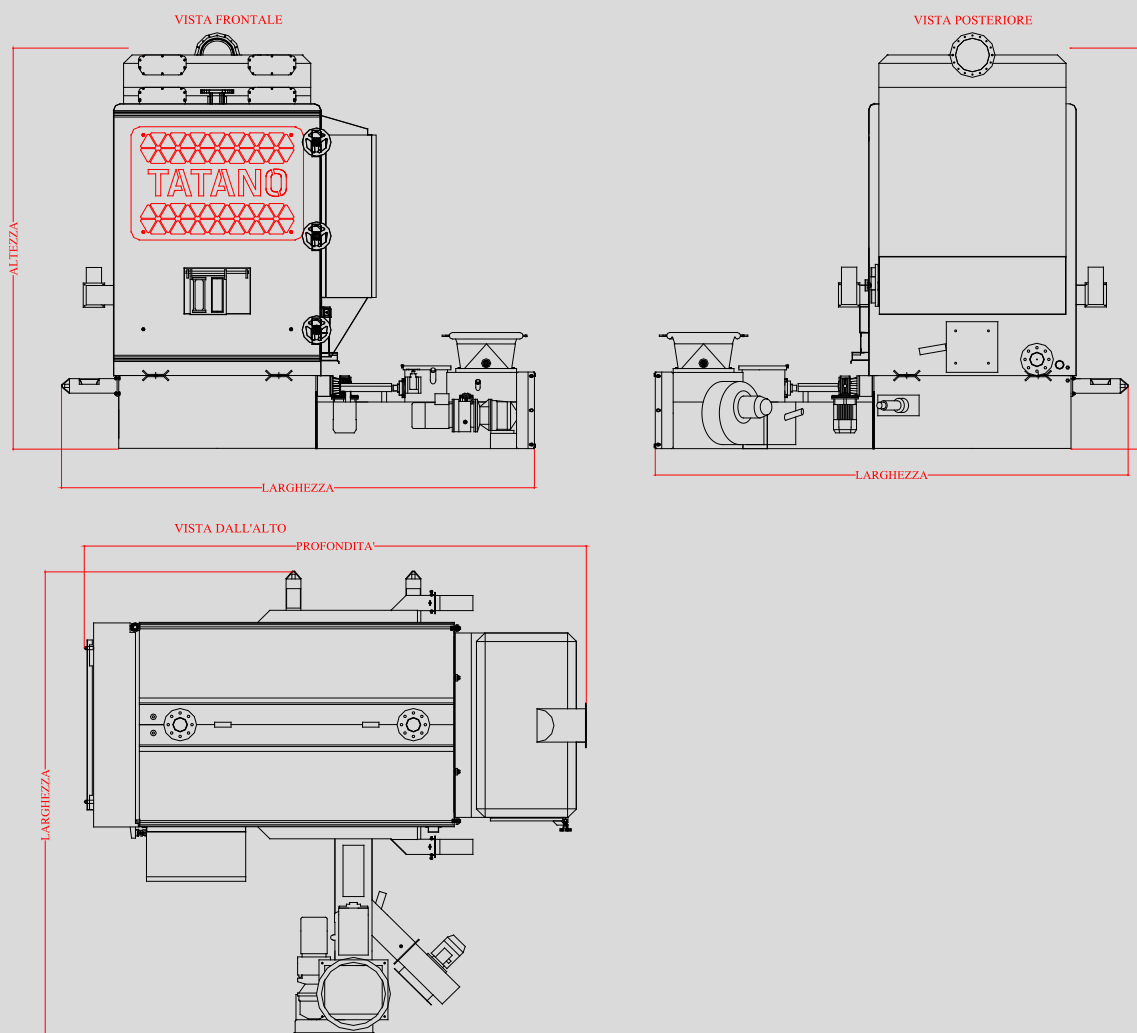

( 1 ) The Dimensions may vary depending on the hopper position (right or left), on the control panel position or according to the optional accessories or for constructive choices.

( 2 ) All the data concerning the consumption and the environmental emissions may vary according to the characteristics of the fuel used, on the operating condition and by the presence of systems for the treatment of fumes.

( 3 ) The data may vary according to the electrical components installed (motors, fans, etc.). The actual data will be reported in the plate affixed to the boiler.

The company reserves to modify dimensions and characteristics without notice, accepts no responsibility for transcription or printing errors.